

# Soak in the Sunshine



Solar Hot Water

# Soak in the sunshine, and SAVE with solar hot water from Chromagen



USES UP TO  
**80%**  
LESS  
ENERGY

With a solar hot water system from Chromagen, you can literally soak in the warmth of the sun whilst reducing your water heating bills. These highly efficient water heaters use the sun's unlimited and free energy to pre-heat your water, using up to 80% less purchased energy than conventional hot water systems.

## Efficient living with Chromagen

Chromagen, a pioneer in the production of solar water solutions has a long history of innovation and excellence. Founded in 1962, the Chromagen brand is a major international player in thermal solar technology. Chromagen's world-class solar hot water systems are sold to over 35 countries and are recognised across the globe for their high quality, reliability and durability.

Today, Chromagen Australia distributes a wide range of residential and commercial solar and energy solutions, including the renowned solar hot water systems.

With a commitment to providing quality & sustainable environmental solutions for Australian consumers, Chromagen Australia has a nation-wide presence with a network of offices, dealers and service agents across the country, so you can count on local experience, solutions and service.

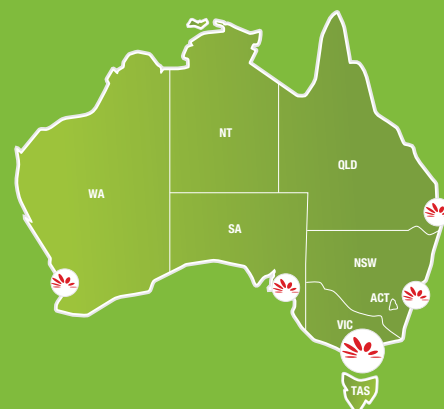

## The range



### Split Configured Systems (*SplitLine & SmartLine*)

- Includes a split configuration of a ground-mounted tank and roof-mounted thermal collector/s
- Provides an aesthetically pleasing rooftop appearance
- Requires a pump to circulate water through the collectors

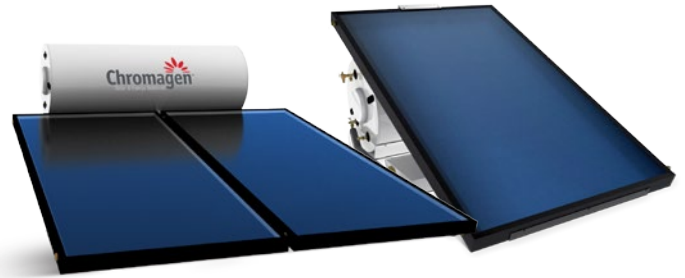

### Roof Mounted Systems (*RoofLine & LowLine*)

- Includes a roof-mounted tank & collector/s
- Ideal where ground space is limited
- Uses natural thermosiphon convection or a solar pump to circulate water efficiently through collectors

## Reliable solar-heated water, on tap

Hot water is a basic household need and there are few things more soothing than soaking in a warm shower or bath. There are, however, few things more frustrating than running out of hot water just when you want it, but with a Chromagen solar hot water system, reliable, environmentally-friendly hot water is on tap.

### The solar advantage:

- Solar pre-heated water significantly reduces power consumption & power bills
- Improves the energy efficiency of your home
- Reduces emissions of harmful greenhouse gases
- Provides a reliable supply of hot water in any weather or time of day

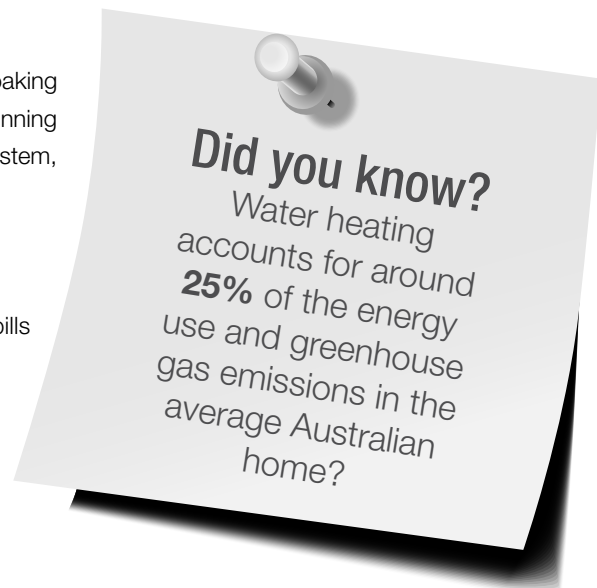

Annual Running Cost Comparison (SAUD)

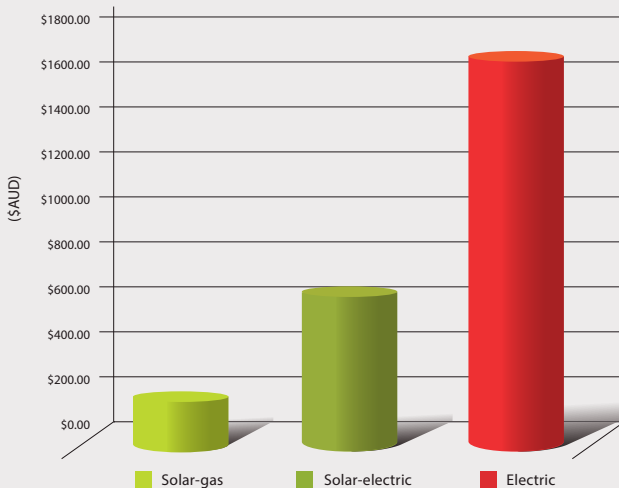

## Energy efficiency

Old energy-hungry electric hot water heaters are very expensive to run and are a huge contributor to household energy consumption, but with solar hot water you could save over \$1000\* per year!

You save so much because most of the heating comes FREE from the abundant Australian sunshine and less electricity or gas is required. When you use the sun to heat your water, you are not only saving money today, you are also reducing your carbon footprint, for a cleaner environment tomorrow.

\*Based on a daily hot water demand of 300 litres, an electricity cost of \$0.30/kWh, gas cost of \$0.02/MJ and on installation in Zone 3. Excludes water costs.

## Split Configured Systems

Chromagen's split configured solar hot water systems consist of a ground mounted tank and roof mounted collectors, and have been designed to provide energy efficient water heating and installation flexibility, without compromising the aesthetics of the home.

Split configured systems are available with the choice of flat plate or evacuated tube collectors to best suit each individual application along with a storage tank, available in a variety of sizes to suit a variety of applications.

All split configured systems are available with the choice of either gas or electric auxiliary boosting to provide reliable hot water in any weather, and to meet the power requirements of your specific location. Gas boosted models feature a highly efficient Midea continuous flow water heater while the electric-boosted models feature an in-tank heating element to supplement the heating required on days of high consumption and/or low solar gain.

Image: Gas boosted SplitLine system with dual BlackMax collectors



## SplitLine with Flat Plate Collector



Storage Tank		Standard (150L / 200L)	Large (300L)	X-Large (400L)
Thermal Collector	Flat Plate: EcoBlue	1 Panel	2 Panels	2 Panels
	Flat Plate: BlackMax	2 Panels	2 Panels	2 Panels
Auxiliary Boost Options	Gas	✓	✓	✓
	Electric	-	✓	✓
System Configurations	Open Loop	✓	✓	✓
	Closed Loop	-	-	-
Frost Protection	Auto Temp Regulation	Standard Inclusion		
	Mechanical Frost Valve	Required in Frost Prone Areas		

## SplitLine with Evacuated Tube Collector



Storage Tank		Standard (150L / 200L)	Large (300L)	X-Large (400L)
Thermal Collector	Evacuated Tubes	20 Tubes	30 Tubes	40 Tubes
Auxiliary Boost Options	Gas	✓	✓	✓
	Electric	-	✓	✓
System Configurations	Open Loop	✓	✓	✓
	Closed Loop	-	-	-
Frost Protection	Auto Temp Regulation	Standard Inclusion		
	Mechanical Frost Valve	Not Required		

### Collector Orientation Allowance

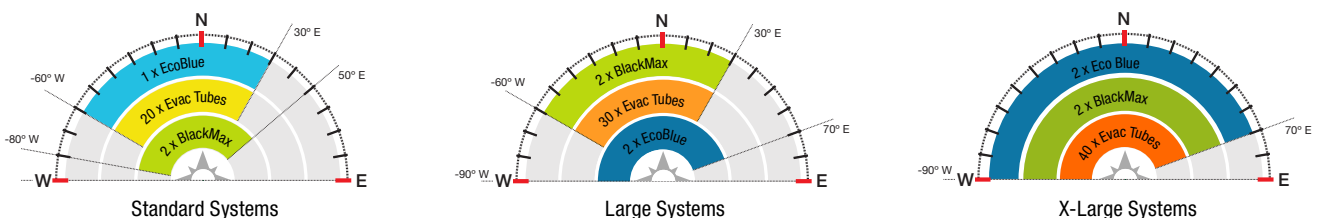

## How Chromagen's SplitLine Solar Hot Water Works:

1. Roof-mounted thermal collectors harness the free abundant heat energy from the sun
2. Water from the tank is circulated via a small pump through the roof-mounted collectors and is heated
3. The heated water returns to the tank and is stored for later use
4. On days of high consumption and/or low solar gain an in tank electric element or gas continuous flow booster assists in reaching the desired water temperature





## SmartLine with Flat Plate Collector & Integrated Gas Booster



Storage Tank	Standard (150L / 200L)	
Thermal Collector	Flat Plate: EcoBlue	1 Panel
	Flat Plate: BlackMax	2 Panels
Auxiliary Boost Options	Gas	✓
	Electric	-
System Configurations	Open Loop	✓
	Closed Loop	-
Frost Protection	Auto Temp Regulation	Standard Inclusion
	Mechanical Frost Valve	Required in Frost Prone Areas

SmartLine system not available in all States.

## SmartLine with Evacuated Tube Collector & Integrated Gas Boost



Storage Tank	Standard (150L / 200L)	
Thermal Collector	Evacuated Tubes	20 Tubes
Auxiliary Boost Options	Gas	✓
	Electric	-
System Configurations	Open Loop	✓
	Closed Loop	-
Frost Protection	Auto Temp Regulation	Standard Inclusion
	Mechanical Frost Valve	Not Required

SmartLine system not available in all States.

### Collector Orientation Allowance

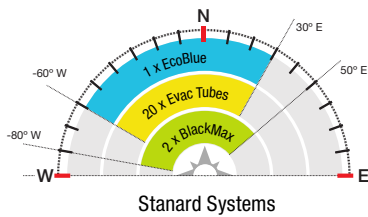

## How Chromagen's SmartLine Solar Hot Water Works:

1. Roof-mounted thermal collectors harness the free abundant heat energy from the sun
2. Water from the tank is circulated via a small pump through the roof-mounted collectors and is heated
3. The heated water returns to the tank and is stored for later use
4. On days of high consumption and/or low solar gain the integrated gas continuous flow booster assists in reaching the desired water temperature





---

## Roof Mounted Systems

Chromagen's roof configured solar water heaters include a range of traditional close-coupled thermosiphon (RoofLine) systems and a specialised low lying (LowLine) 'tank under panel' option. All roof systems bring both the solar collector(s) and storage tank to the one roof location, which make them ideal for applications where available ground space is limited.

The RoofLine range of systems are highly efficient and use natural thermal convection to circulate hot water from the collectors to the tank without the need for electric pumps.

The LowLine system addresses applications where exposed flat roof areas require a more discreet solution to maintain the aesthetics and visual integrity of the building. This variant uses a small electric pump and controller to circulate the water between the collectors and the tank.

Image: RoofLine system with dual BlackMax collectors



## RoofLine with Flat Plate Collector

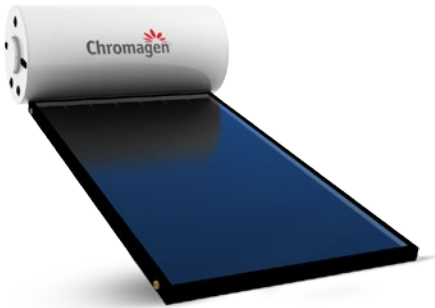

Storage Tank		Standard (200L)	Large (300L)
Thermal Collector	Flat Plate: EcoBlue	1 Panel	2 Panels
	Flat Plate: BlackMax	-	2 Panels
Auxiliary Boost Options	Gas	✓	✓
	Electric	-	✓
System Configurations	Open Loop	✓	✓
	Closed Loop	-	-
Frost Protection	Auto Temp Regulation	-	
	Mechanical Frost Valve	Required in Frost Prone Areas	

## LowLine with Flat Plate Collector

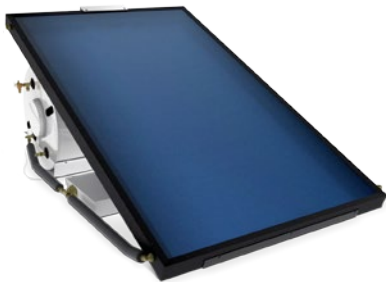

Storage Tank		Standard (200L)
Thermal Collector	Flat Plate: EcoBlue	1 Panel
Auxiliary Boost Options	Gas	✓
	Electric	-
System Configurations	Open Loop	✓
	Closed Loop	-
Frost Protection	Auto Temp Regulation	Standard Inclusion
	Mechanical Frost Valve	Required in Frost Prone Areas

### Collector Orientation Allowance

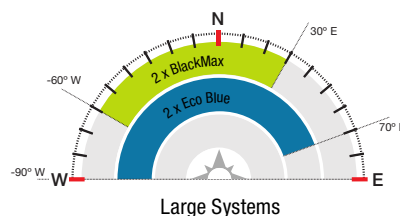
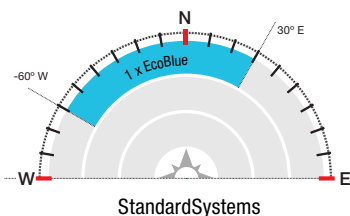

## How Chromagen's RoofLine Solar Hot Water Works:

1. Roof-mounted thermal collectors harness the free abundant heat energy from the sun
2. Water from the tank is circulated through the collectors and is heated
3. The heated water returns to the tank using natural thermal convection, and is stored for later use.
4. On days of high consumption and/or low solar gain an in tank electric element or gas continuous flow booster assists in reaching the desired water temperature

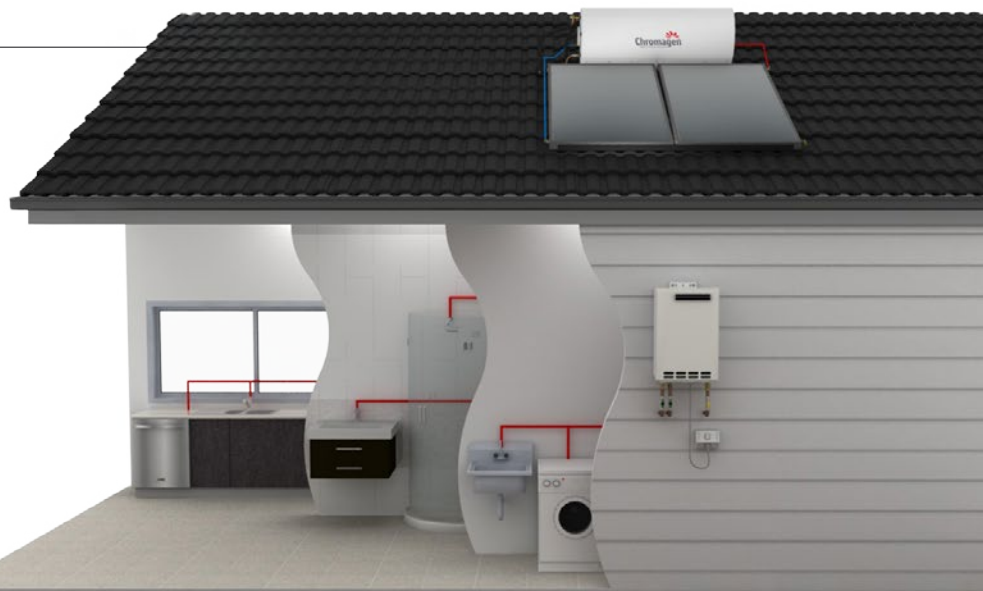

# Component Specifications

## Flat Plate Collectors

Solar hot water systems may include one of two high quality flat plate collectors, including **BlackMax** collectors or the premium **EcoBlue** collectors that consist of the latest "Blue Sputter" coating technology, providing the ultimate thermal absorption properties for ultimate efficiency. The advanced EcoBlue collectors allow Chromagen to offer single-panel system options.



### Residential Warranty

**5 Year** Product  
**3 Year** Labour

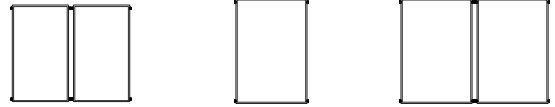

### General Specifications

Model / Type	BlackMax	EcoBlue	
No. of Panels	2 Panel	1 Panels	2 Panels
Total Width x Height x Depth (mm)	2224 x 2187 x 90	1274 x 2187 x 90	2628 x 2187 x 90
Total Gross Area (m <sup>2</sup> )	4.86	2.79	5.75
Aperture Area / Absorber Area (m <sup>2</sup> )	4.28 / 4.10	2.56 / 2.54	5.12 / 5.08
Cover Thickness (mm)	3.2	3.2	3.2
Collector Weight empty / full (kg)	74 / 88	43 / 47	86 / 94
Maximum Pressure (kPa)	1000	1200	1200
Manifold / Riser Diameter (mm)	22.23 / 12	22.23 / 12	22.23 / 12
Heat Transfer medium	Water / Glycol	Water / Glycol	Water / Glycol
Fluid content (litres)	7.1	4.1	8.2

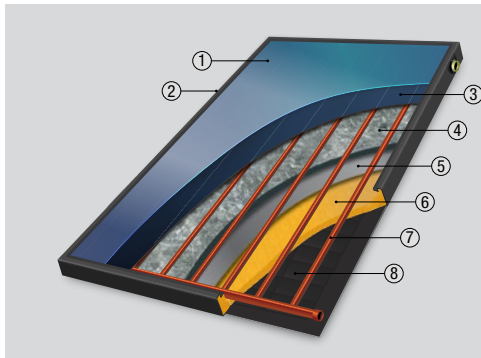

### Material Specifications

	BlackMax	EcoBlue
1 Panel Cover Material	Low iron, tempered glass	Low iron, tempered glass
2 Frame / Casing	Black Coated Galvanised Steel	Black Coated Galvanised Steel
3 Absorber Plate / Treatment	Aluminium / Selective Black Paint	Aluminium / Selective Blue Sputter
4 Upper Insulation	-	Glass wool
5 Insulation Barrier	Aluminium Foil	Aluminium Foil
6 Lower Insulation	Polyurethane	Polyurethane
7 Tube grid material	Copper	Copper
8 Backing Plate	Polypropylene	Polypropylene
Construction Type	Ultrasonically welded plate	Ultrasonically welded plate

## Evacuated Tube Collectors

Evacuated tube collectors are designed to efficiently collect the thermal energy from the sun in a variety of challenging conditions. Utilising a vacuum which allows for the ultimate in heat retention, the tubes themselves contain no water; therefore are not subjected to freezing, making them ideal for cold climates. Along with a single large bore header pipe, evacuated tubes are ideal for hard water applications.



### Residential Warranty

**5 Year** Product  
**3 Year** Labour

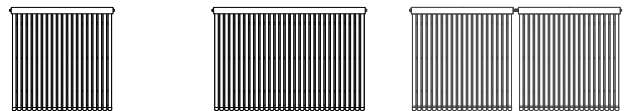

### General Specifications

Model / Type	20 Tubes	30 Tubes	40 Tubes
Total Width x Height x Depth (mm)	1660 x 2020 x 155	2440 x 2020 x 155	3400 x 2020 x 155
Number of tubes per collector rack	20	30	40
Length of tubes (mm)	1800	1800	1800
Total Gross Area (m <sup>2</sup> )	4.1	6.2	8.3
Aperture Area / Absorber Area (m <sup>2</sup> )	1.88 / 1.6	2.82 / 2.4	3.76 / 3.2
Cover tube / Inner tube diameter (mm)	58 / 47	58 / 47	58 / 47
Cover tube glass thickness (mm)	1.6	1.6	1.6
Collector Weight Empty / Full (kg)	79 / 81	119 / 121	158 / 162
Maximum / Operating Pressure (kPa)	1000 / 600	1000 / 600	1000 / 600

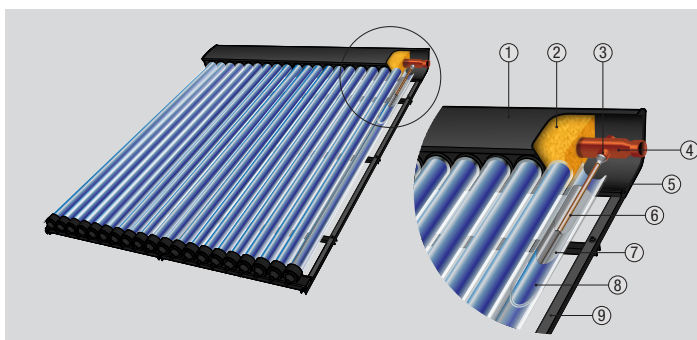

### Material Specifications

1 Header block & mounting Frame	Black coated aluminium
2 Header pipe insulation	Polyurethane, mineral wool foam
3 Heat pipe absorber	Copper
4 Header pipe	Copper
5 Outer tube (Twin layer with vacuum)	Borosilicate glass 3.3
6 Heat rod	Copper with internal heat exchanger fluid
7 Inner tube	Aluminium
8 Inner tube absorber surface treatment	Ultra-selective coating

## Storage Tanks

Chromagen's thermal tanks are specifically designed for the efficient storage of solar-heated water. Our world-class thermal storage tanks are the result of decades of design evolution. This has resulted in a product with state-of-the-art engineering, rugged construction and carefully selected materials, providing the ultimate in thermal insulation and a long service life in Australia's harsh conditions.

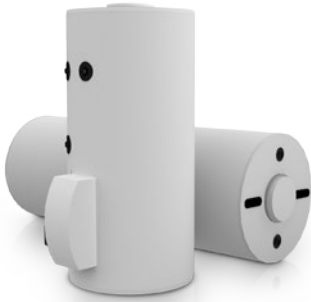

### Residential Warranty (Applicable to Tank Cylinder)

**5 Year** Product  
**3 Year** Labour

### General Specifications

Tank Orientation	Vertical			Horizontal	
	Standard*	Large	Extra Large	Standard	Large
Storage Size	Standard*	Large	Extra Large	Standard	Large
Storage capacity (L)	150 / 200	300	400	200	300
Diameter (mm)	585	651	650	585	585
Height / Length (mm)	1043 / 1241	1434	1765	1241	1809
Cold water inlet (mm from base)	298 / 281	261	271	162	162
Sensor point (mm from base)	298 / 281	261	450	-	-
Hot outlet (mm from base)	745 / 939	1051	1466	468	468
Collector cold flow (mm from base)	298 / 281	261	271	162	162
Collector return (mm from base)	568 / 611	620	630	162	162
Dry weight (kg)	50 / 65	91	126	65	97

\* Standard tank uses 150L tank for single flat plate & evacuated tube collectors / 200L tank for dual flat plate collectors

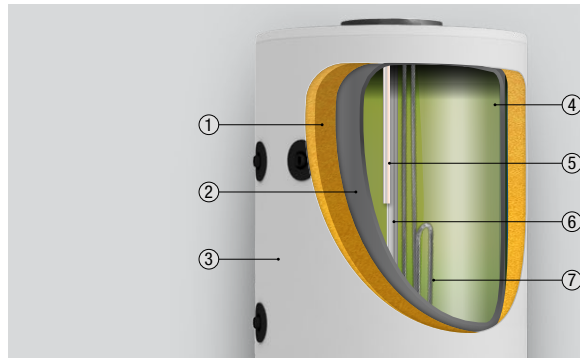

### Material Specifications

1	Insulation	Thick polyurethane layer
2	Storage tank	Mild steel
3	External coating	Baked polyester coated galvanized steel
4	Internal coating	Vitreous enamel layer
5	Built in thermostat	Pre-set temperature setting (Electric systems only)
6	Sacrificial anode	Magnesium
7	Electric element	Auxiliary boost (Electric systems only)

## Auxiliary Boosting

### Gas Boosting

When there's not enough solar to get the job done, a Midea gas boost will supplement the heating required to ensure you are never without hot water. Featuring a high 6+ Star energy rating, these units are highly efficient, heating water on demand.



### Residential Warranty

**10 Year** Heat Exchanger  
**3 Year** Parts & Labour

### General Specifications

	M20	M26
Model	M20	M26
Energy Star Rating	6.5	6.3
Thermal Efficiency (%)	84.1	84.0
Flue System	Forced Flued External	
Rating (l/min @ 25°C rise)	20	26
Nominal Gas Consumption (MJ/h)	160	200
Weight (kg)	16	21.5
Height x Width x Depth (mm)	595 x 375 x 165	645 x 413 x 195
Water connection diameter (mm)	15 BSP	
Gas connection diameter (mm)	20 BSP	
Water Pressure Min / Max (kPa)	150 / 1000	
Water Pressure Optimal (kPa)	350	
Min operating flow rate (l/min)	2.5 (min 3.0 for start up)	
Anti-frost	Standard	
Power Supply Mains Voltage (AC)	240V / 50Hz	
Power Supply Controller Voltage (DC)	12	
Ignition	Electronic	
Gas Types	Natural Gas / LPG (Propane)	

### Electric Boosting

In electric only areas, tanks are fitted with an in-tank electric heating element to increase the heat of the stored water on days of high consumption and/or low solar gain.



### Residential Warranty

**1 Year** Product  
**1 Year** Labour

### General Specifications

Model	2.3	3.6
Capacity	2.3kW	3.6kW
Length (mm)	820	820
Weight (kg)	0.5	0.5

Note: above lengths applicable to vertically fitted elements only

NOTE: An approved tempering valve must be fitted on the hot water outlet from the gas booster (for gas systems) & on the hot water outlet on the tank (for electric systems). WARNING: Do not use plastic pipe between the storage tank and solar collector panels. To do so will have catastrophic consequences. Insulation of copper flow and return lines must be in accordance with AS 3500.4 industry standard.

## Flat Roof Stand

For flat or low pitched roofs, collectors can be mounted with an optional stand to ensure they are angled for the best solar gain. Specialised stands are also available for collector and tank mounting for RoofLine systems to maintain the natural solar convection.



### Collector Only

Model / Type	1 x Flat Plate Collector	2 x Flat Plate Collector	20 x Evacuated Tubes	30 x Evacuated Tubes
Dimensions (H x W x D) (mm)	1125 x 1800 x 2050	1125 x 1800 x 2050	1125 x 2440 x 2050	1125 x 2440 x 2050
Recommended Leg Spacing	920	1500	780	1170

\* Height shown as maximum. Stand is adjustable



### Collector & Tank

Model / Type	1 x Flat Plate Coll. w/ Tank	2 x Flat Plate Coll. w/ Tank
Dimensions (H x W x D) (mm)	1150 x 1800 x 2560	1150 x 1800 x 2560
Leg Spacing	920	1500

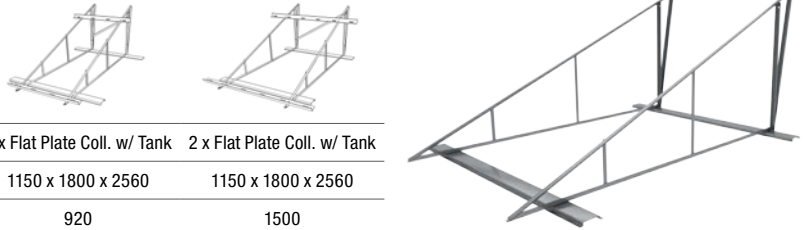

### Residential Warranty

1 Year Product ..... 1 Year Labour

## Solar Pump & Control Station

All split systems include a low energy consumption solar pump and an advanced solar controller kit. The included controller is a differential thermostat controller that continuously monitors the temperature difference between the tank sensor and the roof mounted collector sensor and in turn controls the solar circulation for the most efficient operation.



### Residential Warranty

1 Year Product ..... 1 Year Labour

### General Specifications

1 Solar controller	Providing reliable management of solar heating for most efficient operation
2 Circulation pump	Quality Grundfos circulation pump for efficient & dependable service
3 Warning indicators	Visual LEDs with audio alerts for error notifications
4 Sensor leads	Providing communication between the panels, tank and controller
5 Flow valve control	Controlling the solar flow for maximum heat transfer
6 Housing	Unique two piece plastic housing for greater integration with storage tank

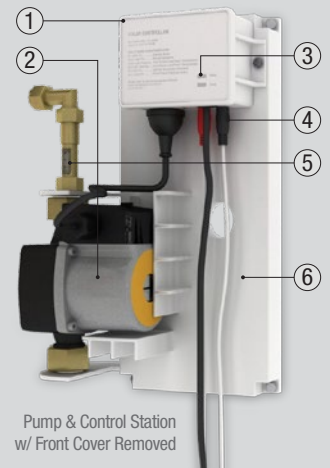

Pump & Control Station w/ Front Cover Removed

## Wireless Solar Controller & Sensor (Optional)

The latest in solar control is the optional advanced wireless solar controller kit, which includes a wireless enabled controller and a wireless collector sensor, eliminating the need for a physically hard wired connection between the tank mounted controller and the roof top collectors. This advanced controller is fully automated and does not require any adjustment or configuration.



Wireless Panel Sensor



Mech. Frost Valve

## Frost Protection

Chromagen pumped systems can employ two control methods against frost, this includes:

1. Automatic Temperature Regulation (Standard inclusion): Activated by the solar controller, the pump circulates water through the collectors to reduce the likelihood of water freezing in the panels.
2. Mechanical Frost Valve (Optional extra): Designed to open at a low temperature to allow water flow through the solar collectors to prevent the formation of ice inside the collector and pipe work.

### Residential Warranty

1 Year Product .....

1 Year Labour

Hot Water Solutions by  
**Chromagen**<sup>TM</sup>  
 Solar & Energy Solutions

chromagen.com.au | 1300 367 565

Solar Water Heaters | Continuous Flow Water Heaters | Heat Pump Water Heaters | Solar Power Systems

# Owner's Care & Maintenance Guide



**ATTENTION SITE SUPERVISOR / INSTALLER!**

**ENSURE YOU TAKE YOUR CUSTOMER THROUGH THE FINAL 'CUSTOMER HAND OVER PROCESS' OUTLINED ON PAGE 2.**

Chromagen Residential  
Solar Hot Water Systems

# Customer Hand Over Process

Congratulations, on the installation of your new solar hot water system which is one the most efficient ways to heat water for your home. Before you start using your hot water system your builder / installer will take you through the following, ensuring your system has been fully installed and is operating correctly.



## Overview explanation on how your solar hot water system operates

1. Roof-mounted collectors harness the heat energy from the sun.
2. Water from the tank is circulated through the collectors and is heated.
3. The heated water returns to the tank and is stored for later use.
4. At night or cold days an electric or gas booster assists in reaching the desired water temperature.

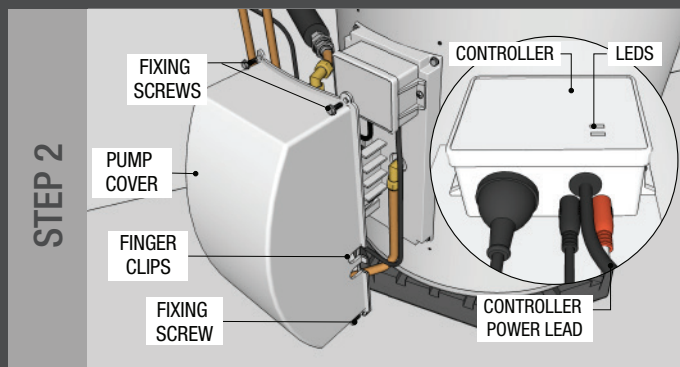

## Demonstration of the solar controller & explanation of the beeping alerts and LED codes (Cover to be removed)

Flashing Red Light Plus Continuous Beeping:	Panel Sensor Lead Fault / Disconnected
Flashing Green Light Plus Two (2) Beeps:	Tank Sensor Lead Fault / Disconnected
Solid Red & Green Lights Plus Three (3) Beeps:	No Solar Circulation Detected
Solid Green Light Plus Four (4) Beeps:	Sensor Outside of Normal Range

**If an issue exists the controller will start beeping and LED lights will flash. If your system starts to beep please contact Chromagen**

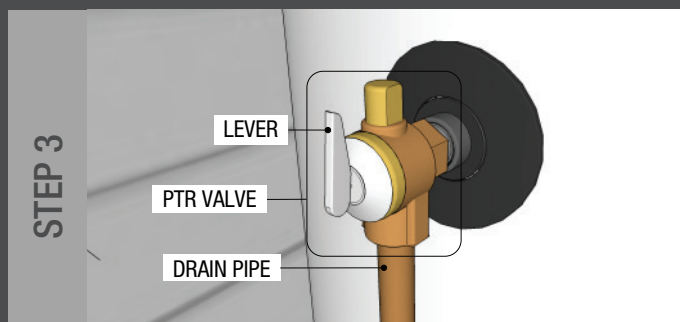

## Demonstration on the operation of the PTR (Pressure & Temperature Relief) valve and associated cautions

Relieve the valve using the lever to ensure this has successful operation (Note: stand clear as water will be released and can be extremely hot) On very hot days or extended periods of low hot water use, the PTR may periodically release water to relieve pressure or high temperature water. This is normal operation and is a safety feature of your system.

**It is recommended to relieve the PTR valve once every six months**

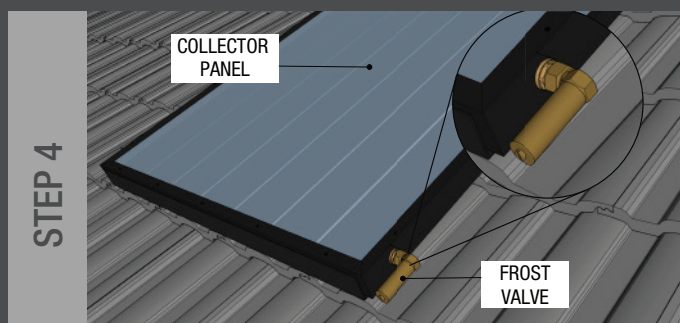

## Checking for suitable frost valve installation and explanation on its protection (where applicable)

Check if your system has a frost valve fitted to one of the lower connections on your roof top panels and ensure it is facing downwards. The frost valve is designed to open at low temperatures to allow water displacement and prevent the formation of ice inside the collector.

**If your system is without a frost valve or your valve is pointing upwards then your system has no mechanical frost protection.**

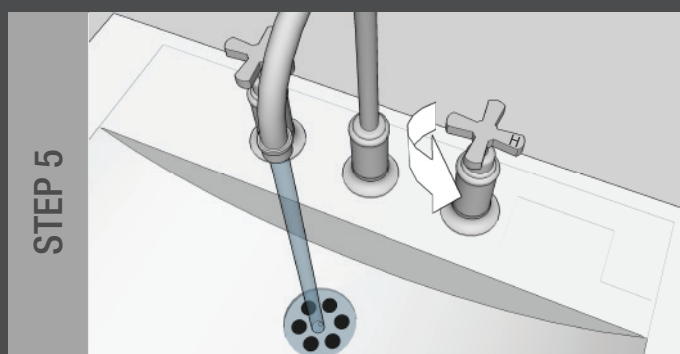

## Demonstration of hot water from numerous outlet throughout the home (Ideally shown using a mixer tap)

Finally check that hot water is getting through to your home by simply turning on a few hot water taps in multiple locations.

If you experience any issues with hot water flow from a specific tap, we suggest you open a second tap to see if this relieves the issue. If so, the hot water unit is working correctly and your tap ware may need to be revisited. In this case to ensure suitable flow of hot water the mixer tap may need to be fully opened towards hot, and once hot water flows then be regulated back to a suitable temperature.

# Warranty / Service

## Getting the best from your Solar Hot Water System

### Registering your Warranty

Keep on top of your new system by registering your warranty and we will send you timely reminders with tips and maintenance steps.

To register your warranty simply complete the online form at [www.chromagen.com.au/warranty](http://www.chromagen.com.au/warranty)

### Arranging a Maintenance Check

As with many modern day appliances, routine maintenance checks and preventative processes can be employed to ensure the prolonged life of your product. Many of these process can be completed by the home owner and by registering your product we will give you the necessary tips to do so.

To arrange a maintenance check please contact our service department on 1300 367 565

### Arranging a Service

In the event that you run into an issue with your product, our friendly service team are here to assist.

To arrange a service please contact our service department via our online portal at [www.chromagen.com.au/service](http://www.chromagen.com.au/service)

### Making a Warranty Claim

In the unfortunate circumstance you run into trouble with your product and you're product is still under warranty then we will waive the cost of the replacement part.

Please note installation costs may occur if a claim is made outside the nominated labour warranty period.

Please refer to the warranty terms and conditions in this document.

### Knowing your model

It is helpful for you to know the model number and / or serial number of your system in the event that you need to contact Chromagen or one of its dealers for advice.

1. If you have a split system, you can find this information labelled on the water storage tank
2. If you have a thermosiphon system and:
  - a. Your system was installed during the construction of your home, then you simply need to provide Chromagen with your installation address.
  - b. Your system was installed by a dealer, then the person who installed your system will have this information

**SYSTEM SPECS**

System Manufacture	Chromagen Solar Solutions
Tank Model	205V
Storage Capacity	200 Litres
Maximum Operating Pressure	1000 kPa
Maximum Supply Pressure	850 kPa
Minimum Supply Pressure	50 kPa
Protection Code Index	IPX4
Rated Voltage	230 V
Rated Frequency	50 Hz
Rated Input Power	2300 W
Thermostat Setting	60°C
PTR Valve Setting	1000 kPa
PTR Valve Power Rating	10 kW
System Compliance Standard	AS/NZS 3498:2009
Type of Construction	Vitreous Enamel
Electrical Certification Number	SA-11100765A

**SYSTEM WARNINGS**

**SERIAL NUMBER**

S/N: **0130901319**

**Warning:** A 100kPa Pressure Temperature Relief valve must be fitted on the storage tank connected with a permanently open discharged pipe positioned facing down. The valve or drain valve outlet pipe must not be sealed or blocked. The valve must be operated every 6 months by holding the cap to remove lime deposits and verify no blockages. Water may drip from this pipe during normal operation.

**Warning:** For continued safety of this appliance it must be installed, operated and maintained in accordance with the manufacturer's instructions.

**Warning:** Appliance not intended for use by persons (including children) with reduced physical, sensory or mental capabilities, or lack of experience and knowledge.

**Danger:** The operation of the thermal cut-out indicates a possibly dangerous situation. Do not reset the thermal cut-out until the water heater has been serviced by a qualified person.

**Note:** A pressure reducing valve is to be fitted in the installation.

# Understanding your Solar Water Heater

## What type of Chromagen solar water heater do you have?

### Split (pumped) system:

With this type, the water storage tank is located on the ground next to the premises and the solar collector panels are located on the roof. A small, efficient pump is used to circulate water from the tank through the collectors.

Depending on the orientation of the roof and the size of your tank, you may have one, two or more collector panels. The solar collector panels may be of a glazed flat plate type, or an evacuated tube type.

### Thermosiphon system:

These traditional systems have both the water storage tank and solar collector panels mounted to the roof in a close-coupled arrangement.

They don't require a pump because circulation of the water happens naturally via the thermosiphoning of hot water up the panels and into the tank, pushing the cooler water out of the tank and back through the collector.

## How Chromagen solar water heaters work

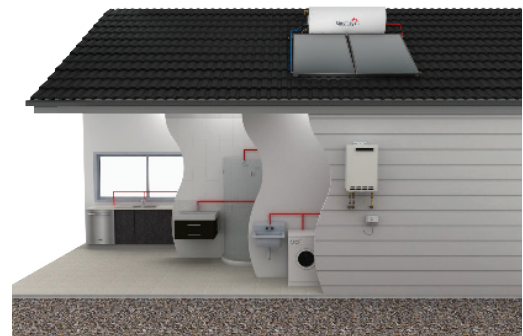

### Split Systems

1. The dark roof top solar collectors (flat plate or evacuated tubes) absorb the free heat energy from the sun
2. Water is pumped through the roof top collectors where it absorbs this heat
3. The heated water returns to an insulated tank, and is stored for later use
4. If the solar contribution during the day is insufficient to meet a suitable temperature, a gas or electric back-up will activate automatically so you will have reliable hot water when you need it

### Thermosiphon Systems

1. The dark-coloured roof top solar collectors absorb the free heat energy from the sun
2. Water naturally circulates through the collectors where it absorbs this heat and rises to the tank for later use
3. Heated water displaces cooler water in the tank forcing it back down to the collectors to be heated
4. If the solar contribution during the day is insufficient to meet a suitable temperature then a gas or electric back up will activate automatically, so you will have reliable hot water when you need it

## How the "booster" of solar water heaters work

A "booster" is the term given to a supplementary heating source that is used as a back up to the primary heating source; solar. In times of continuous cold, overcast weather, the solar gains from the solar collectors may not be sufficient to reach the required water temperatures. In these times, your system will automatically employ either a continuous flow gas water heater, or an in-tank electric element to achieve the required water temperature.

### Gas-boosting

If you have a gas-boosted system, it will utilise a 6 Star continuous flow gas water heater as the supplementary heating source. When a hot water tap is opened, the solar pre-heated water from the tank will go through the gas water heater. If the temperature is sufficient, it will not ignite, however if it is too cool, the thermostat will automatically activate the system giving the water an instantaneous boost of heat before it reaches the tap. When using gas boosting through a continuous hot water system, the gas system should be as close as possible to the most used outlets.

For the gas-boosting to function, the power to the gas water heater must be switched "ON", and the gas line "OPEN" at all times. For operating and maintenance information, please refer to the separate gas manual provided.

### Electric-boosting

If you have an electric-boosted solar water heater, it will utilise an in-tank electric element as the supplementary heating source. A thermostat in the storage tank, checks the water temperature, and if the solar pre-heated water is at a sufficient temperature, the element will not activate, however if it is too cool, the thermostat will automatically activate the element to heat the water until it reaches a sufficient temperature.

Chromagen recommends that the electric element is left "ON" or controlled by a suitable timer.

For the electric-boosting to function:

- The hot water electric isolating switch in the power box is set to the "ON" position
- The electric element isolation switch is "ON"



## Important parts of your solar hot water system

To enable you to care for your hot water system, it is important that you are familiar with the main parts of the system.

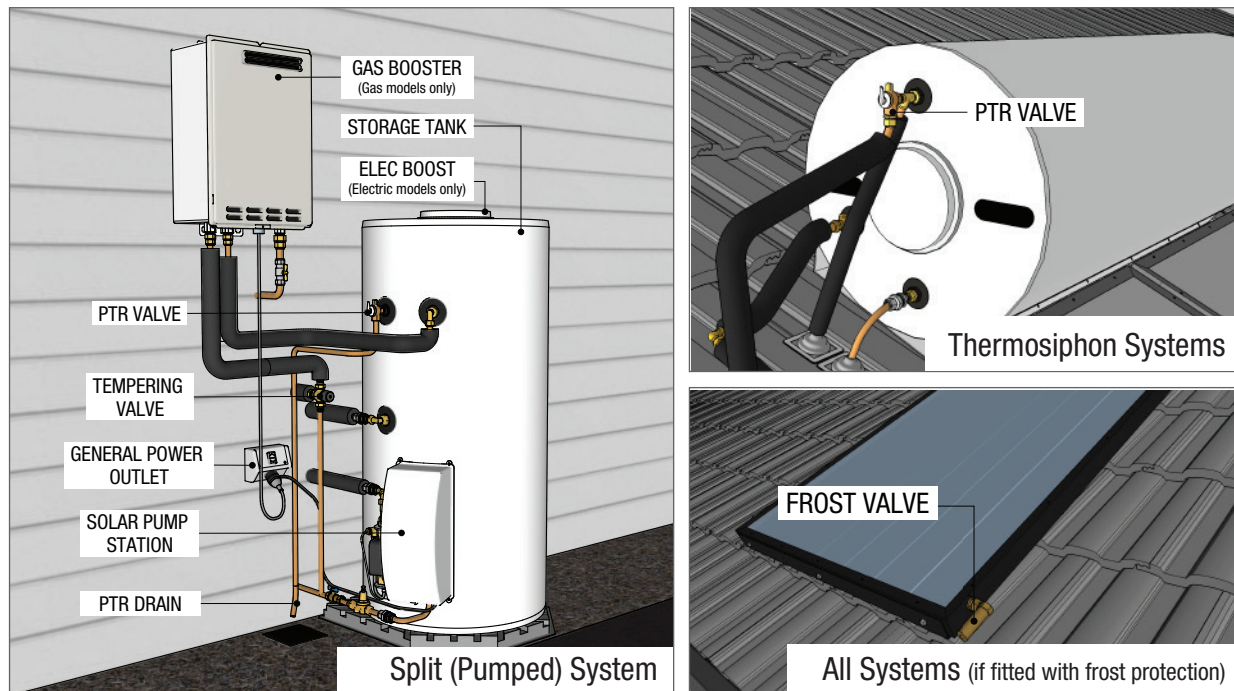

In a solar water heater, the amount of solar energy input will vary from day to day, due to changes in weather conditions. Your system has been designed to allow for extremes in the weather and to minimise the overall purchased energy required to heat your water. Part of the design includes two important safety devices to manage these weather extremes:

### PTR (Pressure & Temperature Relief) valve:

This part is a mandatory safety device designed to prevent the tank from building up too much pressure and / or heat, which may cause damage to the tank. The outlet of this PTR valve must NEVER be obstructed, and must be able to drain freely without damage to people or property.

There may be hot periods of weather when your system may need to discharge a quantity of hot water through the PTR valve. This is a normal operation, however if this discharge is still occurring at air temperatures below 30°C please contact the Chromagen service department for advice.

### Frost valve

A frost valve is also utilised on solar water heaters to protect from damage during extreme cold weather. Frost valves are designed to release a small continuous amount of water when exposed to cold air, to avoid water freezing inside the roof-top solar collectors. If the frost valve on your system continues to release water when the air temperature is over 10°C please contact the Chromagen service department for advice.

## General information and operating guidelines

The general performance and energy savings that you can expect from your Chromagen solar water heater will depend upon a number of factors, such as water usage patterns, daily temperatures, available solar energy and the cost / type of purchased energy being utilised to supplement the energy requirements.

Your Chromagen solar water heater is designed to utilise a combination of solar energy and purchased energy, operating simultaneously, to maintain a minimum operating temperature of 60°C.

To ensure that you always have an adequate supply of hot water, we recommend that the auxiliary booster is left switched ON at all times. The automatic thermostat will switch the auxiliary booster on and off automatically. (Please note: As solar input varies greatly across Australia leaving the auxiliary booster on at all times may not be required).

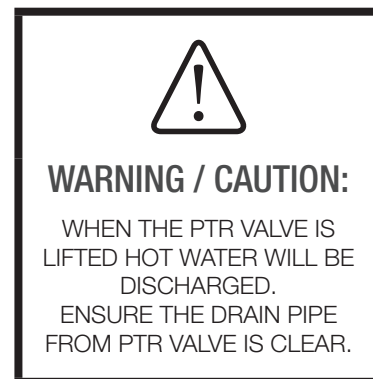

# Maintenance / Troubleshooting

## Looking after your solar hot water system:

To maintain the optimal performance of your system, Chromagen recommends an annual inspection of all valves and safety equipment. Please refer to other maintenance and important information regarding your system below.

### Routine maintenance

Part / Component	Maintenance	Period	Cautions
Roof top thermal collectors	Clean off dust & sediments with a hose	As necessary	Ensure safety from heights
PTR (Pressure & Temperature Relief) valve	Lift the lever for a few seconds, and place back down. This will help prevent a build up of debris or scale in the valve.	Twice per year	Ensure safety from heights The water discharged is HOT. Care must be taken to avoid scalding
Solar Controller (Under pump station cover)	Check the Solar Controller for any flashing LEDs that might indicate a system fault.	Twice per year	Ensure pump station cover is securely refitted after inspection
Anode	Inspection for major degrading	Once per year	Ensure safety from heights
Frost (anti-freeze) valve	Inspection & clean	Once per year	Ensure safety from heights
Complete system	Flush & clean	Every 5 years or as required (dependant on water supply)	Ensure safety from heights

Note that unqualified people should not climb on roof tops. Occupational health and safety regulations must be adhered to.

### Parts that require periodic replacement

Part / Component	Replacement period
PTR (Pressure & Temperature Relief) valve	Every 5 years
Anode	Every 5 years (Inspect & replace if major degrading evident) * Refer to note below

\* Recommended anode replacement interval (guide only): Total dissolved solids (ppm): 0-1000 - 5 years / 1,000 or more - 3 years.

We recommend the installation of a water filter when using water heaters in areas with high levels of total dissolved solids, to maximize the efficiency of the water heater. Please contact your local Chromagen expert for our recommended filters on 1300 367 565

### Collector glass

It is recommended that your household insurance policy cover the collector glass and/or damage to the water heater, especially in cyclonic areas and in locations where hail in excess of 25mm diameter is likely to occur. Damage such as this is not covered by warranty.

### Note about turning off the booster

You should avoid turning off your gas or electric-element booster for normal operation. If you turn it off during the summer months you will risk having inadequate hot water if the summer days aren't hot enough to provide the desired water temperature. There are also health reasons for leaving your booster system ON, because with the booster OFF, the water temperature in the storage tank may not be hot enough to prevent the growth of water-borne bacteria which could lead to Legionnaires disease.

### Note about turning off the circulation pump on split systems

It is recommended that the solar circulation on Split Systems not be turned off at any time during normal operation. Turning off the pump will compromise the automatic in-built "frost protection" function that keeps circulating water through the system during cold weather to prevent the water freezing. If the pump is turned OFF, and damage occurs, this would not be covered by the product warranty.

### What to do if water is turned OFF at your property

If water is turned OFF at your property it is very IMPORTANT that you contact Chromagen's service department to report it, and to discuss essential procedures for turning your solar hot water system back ON. This is required because the pump can be seized by the water supply being shut off unexpectedly.

### Going on holidays / leaving the house unattended

If you are leaving your house unattended for two weeks or more, it is possible for (highly flammable) Hydrogen Gas to accumulate at the top of the water cylinder in the storage tank. To release this gas safely, it is recommended that a hot tap at a sink or bath be turned ON to run a couple of litres of water. If Hydrogen gas is discharged through the tap, it will make a sound like air escaping. When you do this, please ensure there are no open flames, electrical appliances operating or cigarettes being smoked nearby.

## Troubleshooting Guide:

Should your Chromagen system not provide hot water, please check the following before requesting a service call:

1. Check that shading from trees is not excessive and is not covering the collectors for all or part of the day.
2. Check that your hot water usage is not excessive.
3. Check that hot water is not leaking from within the plumbing system.
4. Check the booster is switched ON and/or time switch is turned ON.
5. Check that the booster's circuit fuse or circuit breaker is sound.
6. Check that the electric or gas meter speeds up when the booster switch is turned ON after being OFF.

Contact Chromagen's Service Department if all of the above have been checked and there is still no hot water.

Problem	Cause	Solution
The water isn't hot enough	The gas or electric booster is not operating properly	For gas-boosted systems, check that the power is "ON" & the gas line is "OPEN". (Fig 1) For electric-boosted systems check that the hot water electric isolating switch at the switchboard and that the isolation switch at the tank location is set to the "ON" position.
	Demand may be higher than the system can handle	Contact Chromagen-Service for advice.
	The water temperature has been "tempered" by a Tempering Valve	Tempering valves are required by law. If the tempering valve is faulty, installed incorrectly or at the wrong setting, it will need servicing or replacing.
The Temperature is fluctuating	Fluctuation is localised (i.e. Shower only)	Check flow restrictor of particular item (i.e. Shower head) for any blockages.
	Fluctuation is throughout the whole home	Contact Chromagen-Service for advice.
The pump is not running during sunny weather	The set temperature has been reached in the tank	This is normal. The pump controller sometimes turns the pump OFF to prevent over-heating, if the maximum temp has already been achieved.
	Possible temp sensor problem	Check the Fault Lights on the Control Box located within Solar Pump Station. (Fig 2) A flashing Red or Green light indicates a Sensor lead fault. Check the sensor is securely fitted into the controller (Fig 2) and that the tank sensor lead is securely fitted & sealed (Fig 3). If unsure, contact Chromagen-Service for advice.
The solar circulation pump is running at night	Your system may be automatically activating its "freeze protection" function. In this mode the system runs the pump to circulate water through the system to ensure water doesn't freeze in the pipes and roof top collectors	This is normal operation and is preventing damage, however if the pump is activating several times an hour, additional insulation may need to be used on the collector line to minimise heat loss in the pipe.
	The non-return valve may be faulty	Contact Chromagen-Service for advice.
The solar circulation pump is running constantly, even during cold days	There may be an air-lock in the pipes	Contact Chromagen-Service for advice.
	Insufficient flow rate for pump	
Water is discharging from the PTR valve	The PTR valve is activating because the temperature in the collectors has reached a set limit and the valve is preventing the tank system overheating	This is normal operation. If the volumes are copious please contact Chromagen for advice.
Water is discharging from the frost valve	If air temperature is <u>below</u> 10°C: Frost valve has been activated, releasing water to protect the system	This is normal operation and is preventing damage.
	If the air temperature is <u>above</u> 10°C: the frost valve may be stuck open and/or faulty	Contact Chromagen-Service for advice.

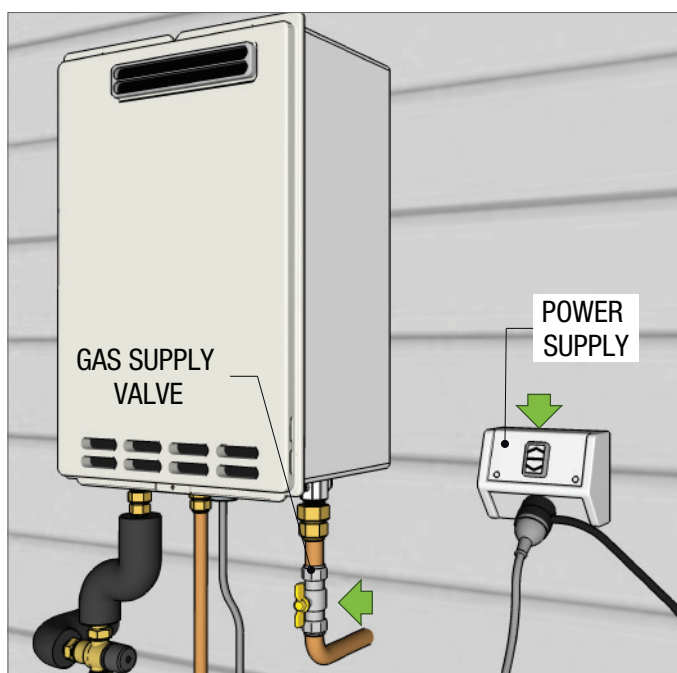

Fig 1

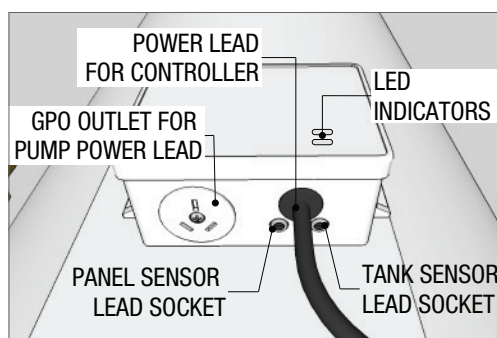

Fig 2

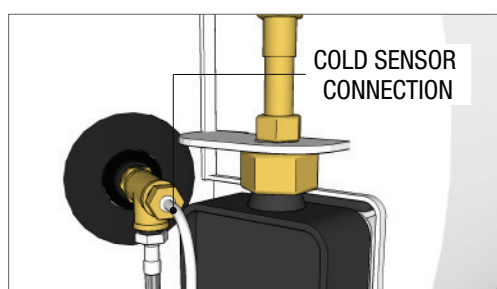

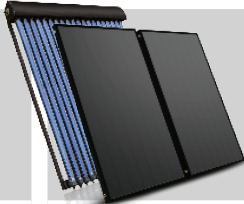

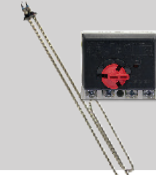



Fig 3

# Product Warranties (Residential Applications)

	STORAGE TANK CYLINDER (ENAMEL)	<b>5 YEARS</b> PRODUCT	<b>3 YEARS</b> LABOUR		THERMAL COLLECTORS (INC FLAT PLATE & EVACUATED TUBES)	<b>5 YEARS</b> PRODUCT	<b>3 YEARS</b> LABOUR	
	GAS BOOSTERS HEAT EXCHANGER	<b>10 YRS</b>	<b>3 YRS</b> PARTS	<b>3 YRS</b> LABOUR		ELECTRIC ELEMENTS / THERMOSTATS	<b>1 YEAR</b> PRODUCT	<b>1 YEAR</b> LABOUR
	GRUNDFOS CIRCULATION PUMPS	SOLAR CONTROLLER	& ALL OTHER PARTS (SUPPLIED BY CHROMAGEN)	<b>1 YEAR</b> PRODUCT	<b>1 YEAR</b> LABOUR			

*Product warranties valid from this documents production date. Images shown are representative only.*

## Specific Exclusions

The above is subject to an area within a 30 kilometre radius of the Chromagen Distributor or Branch from where the unit was purchased. Customers outside this area will be subject to any freight costs and any travelling charges incurred by the Chromagen representative carrying out rectification work.

An 'after hours' service fee will apply to warranty calls made outside of normal business hours. For warranty purposes, typical business hours are classified as the hours from 8.00AM to 5.00PM Monday to Friday (excluding public holidays).

To the extent permitted by law Chromagen does not accept liability under this warranty:

1. If any component of the water heater has been installed, repaired, repositioned or modified by a person other than an appropriately qualified person approved by Chromagen in accordance with Chromagen's installation and maintenance instructions and relevant local and statutory requirements;
2. For loss or damage caused by a fault or defect from installation of water heater;
3. If there is damage to the collector glass by hail or other means;
4. If corrosion has occurred because the anode has not been changed in accordance with the owner's manual;
5. If a cold water expansion valve, check valve and strainer is not fitted in areas where mains pressure is likely to exceed 500 kPa;
6. Where a thermosiphon arrestor valve is not fitted in a thermosiphon system;
7. For any damage arising as a result of an accident, act of god or other circumstances beyond Chromagen's control;
8. If the water heater is a closed loop system and the water heater's closed circuit is not filled with heat transfer or antifreeze fluid approved by chromagen; or the inner cylinder has collapsed as a result of an incorrect filling and/or commissioning procedure; or the addition of water to the closed circuit has not been made in accordance with the water quality specifications (see "water quality" in the installation instruction);
9. For component/system failure due to poor water quality and/or high mineral content (eg CaCo3 etc);
10. For frost damage to Chromagen open loop solar water heaters when installed in a frost prone area without approved frost protection valve(s);
- or due to temperatures below -5°C; or where a failure of the pump, control system or power supply results in the in-built frost protection system being unable to operate when required;
11. For components not supplied by Chromagen that are used in the installation of Chromagen solar water heaters eg. Tempering valves, cold water valve assemblies, etc.
12. For extended or implied warranties not formally provided by Chromagen;
13. For external labour or equipment costs (eg. Cranes and lifting devices) required for repairs;
14. For costs incurred for rectifying faults (or perceived faults) not directly attributed to the Chromagen solar water heater;
15. For travel costs of service agents that exceed 30 kilometres;
16. For all consequential loss or damage arising from defects that can lawfully be excluded;
17. For any other issues not directly attributable to defects in components supplied by Chromagen including:
  - a. damage caused by incorrect commissioning;
  - b. leakage from valves not supplied by Chromagen;
  - c. leakage from the pressure temperature relief valve where the water pressure or temperature exceeds the limits specified in Chromagen's installation and maintenance instructions;
  - d. water hammer;
  - e. external rust on the storage tank;
  - f. insufficient hot water because:
    - the consumer refuses to use the auxiliary booster;
    - of an incorrectly set or faulty tempering or mixing valve;
    - of faulty or incomplete installation;
    - the water heater is too small for its required purpose;
    - of insufficient water flow as a result of "water saving" tap-ware or appliances (for gas water heaters only);
    - of undersized gas lines (for gas water heaters only);
    - of blown fuses, "tripped" electrical switches or inadequate household electrical wiring;
    - of incorrect selection of gas type (gas water heaters only); or
    - insufficient water flow caused by debris accumulating in water strainer (gas water heaters only)

Solar Hot Water by  
  
**Chromagen**<sup>TM</sup>